

# ScientTemp<sup>TM</sup>

3565 S. Adrian Hwy  
Adrian, MI 49221  
Ph: 517-263-6020  
[www.scientemp.com](http://www.scientemp.com)

## Operating and Installation for Super and Ultra Cold Chest Freezers

**For Model's:** 43-1.7 45-3.1 45-6.8 40-9.4 40-12 40-21  
85-1.7 85-3.1 85-6.8 80-9.4 80-12 80-21

**Customer Service / Replacement Parts:**

Email: [tracy@scientemp.com](mailto:tracy@scientemp.com)  
Ph: 517-263-6020 Ext 102

**Technical Support:**

Email: [stuart@scientemp.com](mailto:stuart@scientemp.com)  
Ph: 517-263-6020 Ext 101

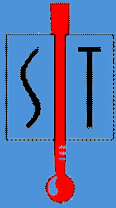

# TABLE OF CONTENTS

---

<b>CONTACTING THE FACTORY.....</b>	<b>1</b>
<b>IMPORTANT BEFORE YOU START.....</b>	<b>1</b>
<b>PRECAUTIONS AND SAFETY.....</b>	<b>2</b>
<b>CHOOSING THE BEST LOCATION.....</b>	<b>3</b>
<b>START UP.....</b>	<b>4</b>
<b>GET TO KNOW YOUR FREEZER.....</b>	<b>4</b>
<b>CAL9500 DIGITAL TEMPERATURE CONTROLLER.....</b>	<b>4-5-6</b>
<b>LID SEAL.....</b>	<b>7</b>
<b>ALARM SIGNAL SYSTEM.....</b>	<b>7</b>
<b>CHART RECORDER (IF EQUIPPED).....</b>	<b>7</b>
<b>HINGES.....</b>	<b>8</b>
<b>MAINTENANCE.....</b>	<b>9</b>
<b>TROUBLESHOOTING.....</b>	<b>10</b>
<b>WARRANTIES.....</b>	<b>11</b>
<b>WIRING DIAGRAM.....</b>	<b>12</b>

# CONTACTING THE FACTORY

For reference and when contacting the factory, please have your freezer information ready:

**Model Number:**

**Serial Number:**

**Date Received:**

\*The Model Number and Serial Number can be found on the data plate attached to the cabinet on the back upper left corner.



## IMPORTANT...READ FIRST

- When uncrating, do not discard the Dark Grey Styrofoam Sublids inside the freezer
  - \* The sublids are necessary to maintain correct temperature, moisture control and economy of operation.
- Make sure your freezer is placed on a level surface and in a well ventilated room. Provide at least 3" of space around the freezer for ventilation. Avoid placing the freezer in locations exposed to direct sunlight or any heat source.
- Alarm On/Off switch should remain in the "Off" position until freezer reaches desired set point temperature. When the temperature has been reached, turn the alarm switch to the "On" position.
- Freezers are pre-programmed for proper operation.
  - \*\*Depending on your specifications, you may need to only adjust the set point.
- Freezer should not be loaded with product until the cabinet has operated for 24 hours at the desired setpoint temperature.
- Caution: When skin is exposed to low temperature conditions, frostbite is possible.
  - \*\*Please wear proper gear to avoid freezing of exposed skin.
- On Model 43-1.7 and 85-1.7 only, the condenser of the freezer is located on the inside wall of the outer case. Therefore, during operation the outer case (or shell) will feel warm to the touch. The heat removed from inside the freezer radiates from the outer case of the cabinet into the air.

For this reason, the outer surface should be kept clean and free of any wrapping, covers or objects that will limit the transfer of the heat from the freezer shell.
- It's recommended to keep the freezer running at a temperature below freezing rather than turning the freezer off and on.
- This freezer is not a \*rapid-freeze\* unit.
- If loading large amounts of product into the freezer at one time, be aware that the inside temperature will increase and may trigger the alarm. (You may turn the alarm off until the unit has fully recovered back to set point temperature)

# PRECAUTIONS AND SAFETY

In this manual, the words WARNING and CAUTION mean the following:

- \*  **WARNING** A potentially hazardous situation, which if not avoided, could result in serious injury or death.
- \*  **CAUTION** A potentially hazardous situation, which if not avoided, may result in minor or moderate injury or damage to equipment.

Before installing, using or maintaining this product, please be sure to read this manual carefully. Failure to follow these instructions may cause this product to malfunction, which could result in injury or damage.

Below are important precautions that apply to this product:

- Use this product only in the manner described in this manual. Before using it, verify that this product is suitable for its intended use.
- Do not modify the cabinet by drilling new holes.
- The cabinet must be properly grounded in accordance with the national and local electrical codes and ordinances.
- Disconnect the unit from all power sources before doing any maintenance or cleaning of the unit.
- If you are storing high value product in freezer, it is recommended that an independent monitoring system be used to monitor and alert you of any issues that may interfere with the freezer's operation.

# CHOOSING THE BEST LOCATION

## MOVING YOUR FREEZER:

*The refrigeration system is designed to operate with the cabinet located on a flat surface.*

***\*Do not tilt the cabinet more than 30° to any side.\****

*If the cabinet must be tilted on an angle for handling or moving purposes, allow it to sit in an upright position for at least two (2) hours prior to plugging in and starting the freezer.*

## THE LOCATION:

### Wiring and Installation:

Your freezer is designed for indoor use only. Please confirm your power supply is adequate and delivers the correct voltage requirements for your new freezer. Operating the freezer with insufficient power can result in severe damage to the compressor and electrical components.

~Voltage requirements for your freezer can be found on the serial tag on back upper left side of your cabinet~

115V cabinets are equipped with a Nema 5-15P three-prong plug for your protection against shock hazards.

Choose a location that is close to a dedicated electrical line with a proper grounded (three-prong) electrical outlet.

**⚠WARNING** \*Do not use an extension cord or surge protector.

**⚠WARNING** \*Do not use an adapter of any sorts.

**⚠WARNING** \*Do not remove or modify the ground pin on the electrical plug.

**⚠WARNING** \*To avoid freezer being shut off....Do not plug freezer into outlet controlled by a wall switch.

**⚠WARNING** \*When unplugging the unit from the wall outlet, never pull on the cord. Always grip the plug safely and pull straight out from the outlet.

### Air Circulation:

The cabinet should be situated in a well ventilated room to allow proper air circulation. Provide at least 3" of space around the entire freezer for ventilation.

\*NOTE: The cabinet must be installed on a sturdy, solid, level floor resting firmly on all four mounting points\*

### Ambient Temperature:

Do not place the freezer in locations exposed to direct sunlight, heat registers or any other heat sources.

Drafts from fans, air conditioning or open doors can also affect the cabinet and product temperature.

The ambient temperature range for the location must be 59° to 90°F ( 15° to 32°C) for optimal freezer performance.

\*When opening the door, avoid leaving it open for extended periods of time. Chamber air will escape rapidly.

Room air, which is higher in humidity, will replace chamber air and may cause frost to develop in the chamber more rapidly

# START UP AND GET TO KNOW YOUR FREEZER

## START UP:

1) Plug in or connect freezer power source

### Interior Compartment Temperature:

The temperature is controlled by a CAL 9500 digital temperature controller. When you first power up the freezer, the high stage compressor and fan will start and operate for 3 to 6 minutes before the low stage compressor freezer, starts. Pull down to minimum temperature will take from 3 to 6 hours, depending on ambient temperature and size of cabinet. The high stage compressor runs 100% of the time. The low stage compressor will cycle on and off to maintain the temperature of the controller setting. Set the control to the desired set point.

2) Set your set point temperature:

To view the set point temperature, press the \* key. Press and hold the \* key and use the up or down arrow to increase or decrease the set point temperature.

Freezers are shipped from the factory with the indicating digital control programmed for proper operation.

## INSTRUMENT PANEL FEATURES

! This page can be photocopied and used as a visual aid and bookmark when working in other parts of the manual.



## ADJUSTMENTS

To enter or exit <b>program mode:</b>	Press ▲ ▼ together for 3 seconds
To scroll through <b>functions:</b>	Press ▲ or ▼
To change <b>levels</b> or <b>options:</b>	Press * ▲ together or * ▼ together
To view setpoint units:	Press *
To increase setpoint:	Press * ▲ together
To decrease setpoint:	Press * ▼ together
To reset latched alarm or tune fail:	Press ▲ ▼ together briefly
To run or Hold a program:	Press * ▼ together for 3 seconds

**Notes:** If in difficulty by becoming "lost" in program mode, press ▲ and ▼ together for 3 seconds to return to display mode, check the INSTRUMENT ADJUSTMENTS above and try again.

When in program mode, after 60 seconds of key inactivity the display will revert to either *inPt : nonE* or, if the initial configuration has been completed, the measured value. Any settings already completed will be retained. During Program Configuration it is recommended that this feature is inhibited. Select **ProG StAY** in Level 4.

# CAL9500 Configuration Data

**\*\*Note: Your CAL9500 Controller is preset to the following settings. No need for programming. This page is for informational purpose only.**

## Level 3

SP1.d – rly

SP2.d – rly

Burn – uP.SC

rEV.d – 1d.2r

rEV.L – 1i2n

SPAn – 0.0

\*Zero – 3 \*Note: only change this parameter if calibrating unit, value may vary

ChEk – off

rEAd - Var

tECh – CtA

Ver – 953

rSET – none

## Level 2

SP1.P – 0

hAnd – off

PL.1 – 100

PL.2 – 100

SP2.A – Dv.hi

SP2.b – none

di SP – 0.1

hi .SC – 100

Lo. SC – -100

in Pt – tc t

unit – C or F

## Level 1

tune – off

band – 0.3

int.t – off

dEr.t – off

dac – 0.5

cyc.t – on.of

ofSt – 0.0

SP.Lk – off

SPrr – 0

SPrn – off

SoAk – --

Set.2 – 8 (alarm deviation)

bnd.2 – 0.1

Cyc.2 – on.of

# FUNCTIONS MENU

**LEVEL 4** Derivative sensitivity 0.1 to 1.0 A def1 (0.5)  
 Display averaging Off; 1 to 32 (6)  
 Disable -AL- alarm  
 Disable program auto-exit  
 Security lock Auto, SxY  
 Change program entry point  
**DEFS** **D.SS** **NOPL** **PROD** **LOC2** **SECL**

**LEVEL 3** SP1 output device name: rly, SSt, ANLG  
 SP2 output device name: SSt, rly (read only)  
 Sensor burn-out uSC at SC; 1u, 2d; 1d, 2u  
 Reverse output 1, 3d; 1d, 2d; 1, 1r; 1d, 2r  
 Reverse OP Eds 1n, 2n; 1, 1r; 1, 1r  
 Span adjustment 0.0 to 25% sensor  
 Zero adjustment 0.0 to 25% sensor  
 Set Monitor Off; on  
 Read Monitor VxY; rly; lo des  
 Read Tune Data CxY; Cb; Ct1; Cb; Cb3; CxY  
 Software version 05.1; US; 052  
 Consult Unit  
**SP1d** **SP2d** **BURN** **REUD** **REUL** **SPRN** **ZERD** **CHEV** **REED** **BECH** **WER** **RSEB**

**LEVEL 2** Read SP1 output % 0 to 100% read only  
 SP1 manual output % 0 to 100% proportional made only  
 Limit SP1 output % 100 to 0%  
 Limit SP2 output % 100 to 0%  
 Main SP2 mode: dLo; bAnd; note; dVx; rly; Coof; 2p  
 Second SP2 mode: note; LIC; hodi; L1, hoi  
 Display resolution 1 or 0 degree  
 Set scale maximum 0.0 Sensor max to sensor full scale  
 Set scale minimum 0.0 Sensor min to sensor full scale  
 Select input sensor name  
 Select display units name; C; F; bN; Psi; Ph; rly; SET  
**SP1P** **HRND** **PL1** **PL2** **SP2P** **SP2B** **D.SP** **H.SC** **LOSC** **RPE** **UNE**

**LEVEL 1** Autotune or Park Off; on; Park-At SP  
 SP1 Prop band (gain) hyst 0.1 des to 100% sensor f/s (10°C/10°F)  
 Integrate time (reset) Off; 0.1 to 60 min (5 min)  
 Derivative time (rate) Off; 1 to 200 sec (25 sec)  
 Derivative approach 0.5 to 100% sensor (1.5)  
 Cycle time or on/off Off; 0.1 to 81 sec (10 sec)  
 Offset (manual test) 0 to 50% x band (int = off)  
 Setpoint lock (SP1) Off; on  
 Adjust SP2 setpoint +/- sensor full scale or full scale  
 SP2 prop band (gain) hyst 0.1 des to 100% sensor f/s (10°C/10°F)  
 SP2 Cycle on/off Off; on; 0.1 to 81 sec  
**LENE** **BRND** **NEB** **DETB** **DRE** **CYCLE** **OFSE** **SP1L** **SEED** **BND2** **CYCLE**

**PROGRAM ENTRY (DEFAULT)**  
 Program number 1 to 31  
 Run program hold: del Off; on; Copy; rly  
 Power failure recovery mode: rly; Cont; hold  
 Program start value P; SP  
 Setpoint ramp time units hour; 60s  
 Segment number 1 to 126 max  
 Define segment type Loop SP; SxK; SP; del; rly  
 Setpoint ramp rate 1 to 999 (100) units/time  
 Adjust target setpoint +/- sensor full scale or full scale  
 Holdback value Off; 0.1 to 150  
 Event output (SP2A or SP2A) name; 2d; 2e; 2d; 2e; 2d; 2e; 2d; 2e  
**PRGD** **RUN** **FR.L** **SEU** **SPRV** **SEB** **EYPR** **SPR** **ESP** **HBU** **EO.P**

**LEVEL 0** Level C only visible when COMMS Option fitted  
 Instrument address 0 to 255  
 Baud rate 1200; 2400; 4800  
 Data format 8N1; 18E1; 18O1  
 Tone activity Off; on  
**RDDR** **BRUD** **DREB** **ABUC**

**LEVEL C** COMMS SETTINGS  
 Soak time interval (10) min Cont; 0.1 to 1400  
 Program re-cycle count Cont; 1 to 999  
 Call sub-program number name; 1 to number of programs  
**S.NE** **PCYC** **SUBP**

**LEVEL R** High scale 1000 -1999 to 9999  
 Low scale 0 -1999 to 9999  
 Input high 50.0 0.1 to 50.0  
 Input low 10.0 0.0 to 49.9  
 Decimal 0000 000.0 or 00.00  
 Main mode none dVx; dLo; bAnd; FxH; ELo; Eop  
 Second mode none LIC; hodi; L1, hoi  
 Set SP2 0 0 to 2500  
 Hysteresis SP2 3D 1-100% sensor full scale  
 Burnout SP2 - uSC dVSC  
 Reverse OP3 3D 3r  
**R.H.** **R.LO** **H.** **N** **L.O.** **N** **DECP** **SP2A** **SP2B** **SEED** **HYS3** **B.RN3** **REU3**

**CONFIGURE OUTPUT** **SAFETY SETTINGS** **CALIBRATION** **PERFORMANCE DATA**

**MANUAL ADJUSTMENTS** **SP2 MODES** **RANGING** **CONFIGURE INPUT**

**LINEAR SCALING AND INPUT SETTINGS** **SP3 MODES** **SP3 ADJUSTMENTS** **SP3 SAFETY SETTINGS**

This page can be photocopied and used as a visual aid and bookmark when working in other parts of the manual.

English

KEY \* ▼ OR \* ▲ TOGETHER TO CHANGE LEVELS OR OPTIONS

KEY ▼ OR ▲ TO VIEW FUNCTIONS

## Lid Seal:

If the lid gasket does not seal along the front edge, you'll need to relieve the compression of the gasket along the back edge of the lid. First loosen (do not remove) the 4 hinge screws where they attach to the cabinet (not on the lid). With the hinge now loose, lift the hinge up slightly to level the lid and then retighten the screws.

**⚠WARNING** \*\*Hinges are spring loaded and under high tension.

## Alarm Signal System:

**On start up:** The Alarm should be kept in the “OFF” position until the cabinet set point temperature has been reached. When the temperature has been reached, switch to the “ON” position.

The Alarm system is an audible and visual signal-warning system. When used in conjunction with a SCIENTEMP low temperature cabinet, it will monitor “temperature-rise” and “power-failure”.

The control is factory set to operate the alarm at approximately 10°F (8°C) above the set point temperature.

- 1. Temperature rise and power failure is indicated by flashing red light accompanied by a repeating audible signal in the form of repeating beeping sound to alert you.
- 2. The Alarm system is powered by two (2) “9 volt” batteries. It is important that the batteries be placed correctly in the holders for the proper polarity. We recommend batteries be replaced once a year to assure performance of the alarm.
- 3. To change Alarm deviation: Press and hold up and down arrows together for 3 seconds until Tune/Off shows. Then press up arrow to get to Set.2. Then press and hold \* and hit up or down arrow to change alarm deviation number. Exit configuration by pressing up and down arrows simutaniously for 3 seconds.

## Testing the Alarm Signal System

Make sure the Alarm is turn to the "On" position. Press the “test button” for frequent checks on battery life and alarm performance. If the alarm fails to operate properly, it may be due to weak battery, which should be checked first.

To simulate “temperature-failure”, lower or raise the set point temperature on the controller to trigger the alarm.

## Chart Recorder (If equipped) :

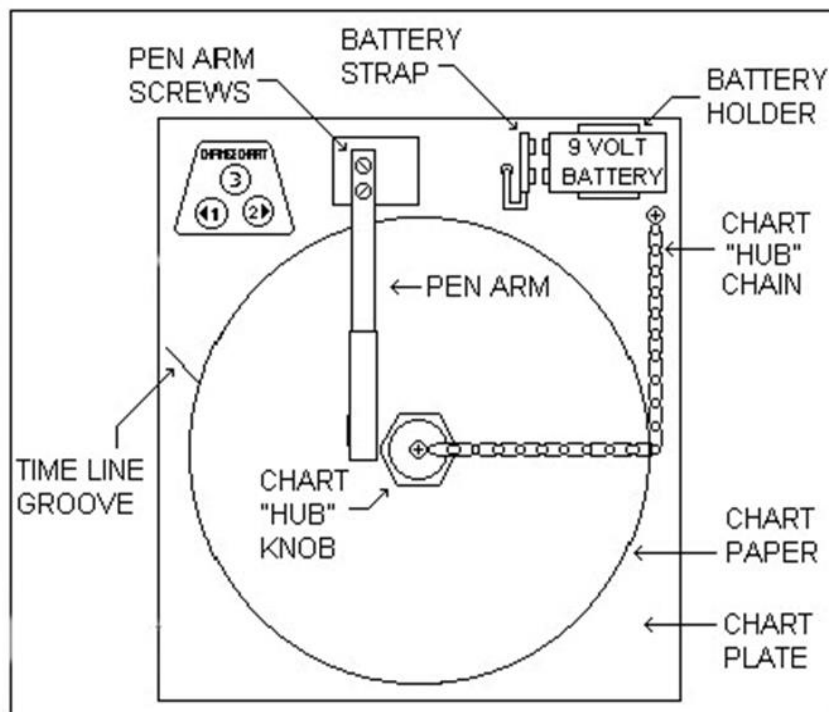

Chart Recorders are an optional item for all chest freezer models. Recorders are used for recording the temperature inside the freezer.

**NOTE:** First connect freezer to power, then connect 9V battery strap to battery. Recorder will start as soon as freezer is connected to power. But may not start to record temperature until freezer reaches the temperature range that the recorder is set up for.

### **Getting started with your recorder:**

- 1) Open cover to access the recorder.
- 2) Make sure recorder has new 6" recorder paper ready for use. If you need to replace the paper, please follow the instructions under "Changing the Chart Paper" section below.

### **Changing the Chart Paper:**

- 1) Locate "Change Chart" key pad on top left corner on recorder.
- 2) Press and hold the Change Chart button. (#3) for approximately 1 second until the metal pen begins to move to the left and then release the button. When the pen has moved completely off of the chart, unscrew (counter-clockwise) the chart "hub" knob located in the center of the paper. Remove the old chart. When installing the new chart, make sure you position the new one so that the correct time line coincides with the time line groove on the chart plate. See Diagram on next page to help with location of the time line groove.
- 3) After you have the new paper in place, re-attach the "hub" knob and make sure its secured in place by hand.
- 4) Press #3 button again for about 1 second until pen starts to move back onto the chart and then release the button.

**NOTE:** If metal stylus is not marking on paper, you may need to remove the arm and adjust it by doing a slight bend to the arm in the middle to make sure it makes contact with the paper.

**NOTE:** The metal arm does not contain ink. Paper is pressure sensitive.

### **Pen Arm Calibration :**

To check and/or adjust the recording pen calibration to the outer most temperature graduation of the chart, press and hold the "change chart" button (#3) until the pen begins to move off of the chart. Once the pen has moved off of the chart, again press and hold the "Change Chart" button (#3) until the pen begins to move back onto the chart. The pen should briefly stop at the outer most temperature graduation of the chart before continuing onto the chart to begin recording. If the pen does not stop exactly at this location on the chart, it can be adjusted or "calibrated" by using the left (#1) or right (#2) arrow buttons.

When the pen moves back onto the chart and briefly stops, you will have approximately 5 seconds in which to adjust the pen's position using the left and right arrow buttons.

### **Temperature Recorder Calibration Check :**

**NOTE:** The recorder has been accurately calibrated at the factory. Before making any adjustments, the freezer with recorder should be in service and running for at least 24 hours.

If any adjustments are needed, perform the following steps:

- 1) Place a Certified Test Thermometer in a solution bottle inside of the freezer alongside or nearest to the recorder's sensor probe.
- 2) Once the freezer and solution level out, compare the position of the pen on the recorder to the test thermometer's reading
- 3) If an adjustment is needed, using the left (#1) and right (#2) arrow, Push button on the recorder to calibrate (or move) the pen's position on the chart to correspond to the temperature of the solution.

**NOTE:** The arrow buttons must be pressed for approximately five (5) seconds before the pen will begin to move.

## Hinges:



**\*\*Hinges are spring loaded and under high tension.**

### If you need to replace the hinges:

\*Tools you'll need: 1/2" Deep Well Socket, 5/16" Nut Driver

#### **First:**

- 1) Open lid
- 2) Using a 1/2" Deep Well Socket turn nut at bottom of hinge. \*See Diagram
  - a) Turn the nut to the left and loosen until the nut is approximately 1/2" from the end.

#### **Second:**

- 1) Close Lid
- 2) Remove the (4) screws from the cabinet first.
  - a) Remove top two and one of the bottom screws first. Because the hinge is under great tension, you'll need to press and hold down the hinge while carefully removing the last screw.
- 2) Next remove the (4) screws on the lid.
- 3) To reinstall, reverse the above procedure.
- 4) Check the lid for alignment and gasket for proper seal. Use the slot hinge holes on cabinet to make any required adjustments.



### Adjusting the hinges:

- 1) Open lid
- 2) Using a 1/2" Deep Well Socket turn nut at bottom of hinge. \*See Diagram
  - a) Turning the nut to the right will tighten the compression.
  - b) Turning the nut to the left will loosen the compression.
3. Make sure the lid sits evenly on all four corners.
4. Proper lid adjustment is achieved when lid stays mid way open.
  - a) After adjustments are made and lid is heavy and still does not stay open, it's time to replace them.

# MAINTENANCE

\*  **CAUTION** Maintenance or repair of your freezer should only be performed by a trained professional.

\*The refrigeration system is hermetically sealed and the fan motor has lifetime lubrication, they requires no maintenance.

~It's recommended to keep the freezer operating at a temperature below freezing rather than turning the freezer off and on.

## **CLEANING THE CONDENSER:**

The finned condenser in the refrigeration compartment of the freezer, should be cleaned of dust and debris about once a year (or more often if the freezer is located where excessive dust and dirt may occur)

To clean the condenser:

- Remove power to freezer.
- Locate the finned condenser.
- Use forced air and a vacuum to clean dirt/debris from the condenser and refrigeration compartment.

Location of condensers:

Model 85-1.7 does not have a finned condenser

Model 85-3.1 condenser can be found in the back of the freezer behind compartment guard.

Model's 85-6.8, 80-9.4, 80-12 condenser can be found by lowering the instrument panel on the front.

Model's 40-21 and 80-21 condenser can be found on the end behind removable door.

## **DEFROSTING THE FREEZER:**

Defrosting: Accumulation of frost may be removed in a couple of ways.

1.) While the freezer is running the frost may be removed with a plastic or wooden scraper or spatula, do not use metal or sharp objects such as an ice pick. This will prevent serious damage to the finish of the inner-liner of the freezer. The frost and ice may be collected in a pan, towel or any device to prevent it from falling to the bottom of the freezer or onto the material stored in the freezer.

Most of the frost and ice collects near the top edge and is easily removed.

2.) In the case where the freezer is not loaded, frost and ice may be removed by disconnecting the power the power until the frost and ice thaw. After defrosting, dry the freezer compartment interior and plug back in. \*\*To help with the defrosting procedure, open lid to allow warm air inside the chamber.

## **MAINTENANCE FOR THE LID GASKET:**

Occasionally check and make sure there is no frost or ice build up on or around the gasket. Keeping the gasket clean and free of ice and frost will help prevent the gasket from getting torn or punctured.

Make sure the gasket is completely connected on all sides and laying flush to the lid.

## **CLEANING THE EXTERIOR AND INTERIOR:**

As needed: Use only a soft cloth and mild cleaners. Do not use harsh solvents or abrasives to clean the interior or exterior of the freezer.

# MAINTENANCE

## CHANGING BATTERIES:

It's recommended to check your accessory batteries regularly and replace if there are signs of corrosion or leakage. Yearly replacement is recommended to ensure your equipment is functioning properly and ready in an event of power failure. Batteries can be found on your freezer in two areas.

- 1) Sonalarm - Found on instrument panel of the freezer. Has (2) 9 volt batteries. Can be accessed from the front by removing the front covers to the battery compartments.
- 2) Chart Recorder - (If equipped) (1) 9V Battery - Found on top right corner of the Recorder.
- 3) CO<sub>2</sub>/LN<sub>2</sub> back up systems (If equipped), will have a 12VDC rectangular battery in refrigeration compartment.

# TROUBLESHOOTING GUIDE

PROBLEM	POSSIBLE CAUSE	SOLUTION
Freezer does not power up / no digital display	1. Freezer not plugged into power supply	1. Plug freezer into dedicated power source (wall outlet)
	2. Power cord not firmly seated in power outlet.	2. Push plug firmly into outlet
	3. No power at outlet	3. Move freezer to different outlet or try plugging something else into outlet to test the outlet.
	4. Fuse Blown or Circuit Breaker tripped	4. Check breaker/ fuse box and make sure that it's not tripped or have blown fuse.
	5. Make sure you have correct voltage at outlet	5. Contact service technician
Freezer is not cooling / Digital Display is on	1. Compressor not running	1. Possibly bad compressor or compressor start components. (Contact service technician)
	2. Possible leak or no refrigerant	2. Contact service technician
	3. Check voltage	3. Make sure there is proper voltage at outlet. (Contact service technician)
	4. Check for proper controller settings	See "CAL9500 Configuration Data" for proper settings
Temperature inside freezer does not reach the desired setpoint temperature / recovers slowly	1. Condenser coils are plugged or dirty <small>*Note: Model 43-1.7 &amp; 85-1.7 does not have a condenser coil.</small>	1. Contact service technician to properly clean coil
	2. Freezer Gasket is dirty or damaged	2. Clean or replace the bad gasket
	3. Ambient temperature is too warm	3. Cool location down and keep away from heat source
	4. Large amounts of warm product was added or too much product	4. Allow Freezer to recover after loading with warm product.
	5. Door may be opened to frequently	5. Warm air entering freezer will cause the freezer to warm up.
	6. Not enough air circulating around freezer	6. Make sure there is at least 3" of space around the outside of the freezer.
	7. Make sure condenser fan motor is operating/spinning in refrigeration compartment.	7. If fan motor is not spinning, determine the reason and fix.
Freezer too cold	1. Controller is set too cold	1. Change temperature
	2. Power relay is faulty	2. Contact service technician
External surface of freezer is warm/hot to touch	1. Warmer than room temperature	1. This is normal at start up. Freezer compressor(s) transfers heat from inside the unit to the outside, through the walls.
Excessive frost build up	1. Hot and humid air	1. This is normal.
	2. Door opened frequently or long periods of time	2. Keeping door closed helps with frost build up.
	3. Door may not be sealing correctly	3. Check gasket area for frost build up. Remove any frost and keep gasket clean. *Also check for damage to the ~ Make sure the lid is flat and seal is seated correctly
Door will not close	1. Excessive frost build up	1. Using a wood scraper carefully remove excessive frost
	2. Hinges	2. Hinges need adjusting (* See "Hinges") for instructions

# TROUBLESHOOTING GUIDE

Compressor will not start - no hum	1. Power cord not plugged in at power source.	1. Plug freezer into power outlet
	2. Wiring improper / loose / disconnected	2. Check wiring
	3. No power to outlet	3. Make sure power outlet has power being supplied to it.
		~Check breaker/ fuse box and make sure that it's not tripped or have blown fuse.
Compressor will not start - hums but trips on overload protector	1. Low voltage to unit	1. Determine the reason and correct.
	2. Starting capacitor defective.	2. Determine the reason and replace.
	3. Compressor motor has a winding open or shorted	3. Determine the reason and correct, replace if necessary.
	4. Extension Cords	4. Do not use extension cord. Must be plugged directly into wall outlet using power cord attached to freezer.

**NOTES:**

---

---

---

---

---

---

---

---

---

---

---

---

---

---

---

---

---

---

---

---

---

---

---

# US / CANADA WARRANTY



## Scientemp

3565 S. Adrian Hwy ♦ Adrian, MI 49221  
800-968-2653 ♦ 517-263-6020 ♦ Fax 517-263-5492

### **Standard Warranty**

**Applies Only Within United States and Canada**

#### **SCIENTEMP WARRANTS TO THE ORIGINAL PURCHASER**

**FIRST 18 MONTHS** – The cabinet and all of its parts, shall be free of defects in material and workmanship under normal use and service for a period of 18 months from the date the unit has been shipped from our facility. Scientemp's sole obligation under this warranty shall be limited, at its option, to either repairing or replacing any part of the cabinet determined by an authorized service agent to be defective. Scientemp reserves the right to repair the freezer at our facilities.

#### **THE SCIENTEMP STANDARD WARRANTY DOES NOT COVER**

**TRANSPORTATION COSTS** – Scientemp shall not be responsible for transportation or incidental costs incurred in connection with the repair or replacement of a cabinet or any of its parts.

**ABUSE, MISUSE, ACCIDENTS** – Scientemp shall not be responsible for parts or assemblies which upon inspection are determined by an authorized Scientemp Service Agent to have been subjected to misuse, neglect, alteration, accident, abuse, damage during transit or delivery, or by fire or flood.

**CONSEQUENTIAL DAMAGES – IN NO EVENT SHALL SCIENTEMP CORP BE LIABLE FOR SPECIAL, INDIRECT OR CONSEQUENTIAL DAMAGES, INCLUDING WITHOUT LIMITATION, PRODUCT LOSS OR PRODUCT SPOILAGE CLAIMS, NOR FOR ANY DELAY IN THE PERFORMANCE OF THIS WARRANTY DUE TO CAUSES BEYOND ITS CONTROL.**

#### **GENERAL**

The standard warranty and any service contract related to the STANDARD WARRANTY shall apply only to the products sold and used within the boundaries of the United States and Canada.

Users may file warranty claims either directly with Scientemp Corp, 3565 S. Adrian Hwy, Adrian, MI 49221, or with the seller from whom the cabinet was purchased. All claims must be supported by information concerning the alleged defect and specifically identified by the Serial Number of the cabinet.

**THERE ARE NO OTHER WARRANTIES EXPRESS, IMPLIED, OR STATUTORY, EXCEPT THIS WARRANTY, WHICH IS IN LIEU OF ALL OTHER WARRANTIES INCLUDING TO THE EXTENT PERMITTED BY LAW, ANY IMPLIED WARRANTY OR MERCHANTABILITY OR FITNESS FOR A PARTICULAR PURPOSE.**

#### **DO NOT DRILL HOLES IN CABINET**

Refrigeration tubing and wiring is routed through the cabinet walls. Leaks, wet insulation or electrical problems caused by drilling holes are not covered by warranty.

# INTERNATIONAL WARRANTY



## **Scientemp**

3565 S. Adrian Hwy ♦ Adrian, MI 49221  
800-968-2653 ♦ 517-263-6020 ♦ Fax 517-263-5492

### **International Warranty**

#### **SCIENTEMP WARRANTS TO THE ORIGINAL PURCHASER**

**FIRST 18 MONTHS** – The cabinet and all of its parts shall be free of defects in material and workmanship under normal use and service for a period of 18 months from the date the unit has been shipped from our facility. Under this warranty, Scientemp will supply replacement parts, F.O.B. Adrian, Michigan, U.S.A., for any part proven defective in material and workmanship. Scientemp is not responsible for supplying the labor required to replace parts and make necessary repairs.

#### **THE SCIENTEMP STANDARD WARRANTY DOES NOT COVER**

**TRANSPORTATION COSTS** – Scientemp shall not be responsible for transportation or incidental costs incurred in connection with the repair or replacement of a cabinet or any of its parts.

**ABUSE, MISUSE, ACCIDENTS** – Scientemp shall not be responsible for parts or assemblies which upon inspection are determined by an authorized Scientemp Service Agent to have been subjected to misuse, neglect, alteration, accident, abuse, damage during transit or delivery, or by fire or flood.

**CONSEQUENTIAL DAMAGES – IN NO EVENT SHALL SCIENTEMP CORP BE LIABLE FOR SPECIAL, INDIRECT OR CONSEQUENTIAL DAMAGES, INCLUDING WITHOUT LIMITATION, PRODUCT LOSS OR PRODUCT SPOILAGE CLAIMS, NOR FOR ANY DELAY IN THE PERFORMANCE OF THIS WARRANTY DUE TO CAUSES BEYOND ITS CONTROL.**

#### **GENERAL**

The standard warranty and any service contract related to the STANDARD WARRANTY shall apply only to the products sold and used outside the boundaries of the Continental United States.

Users may file warranty claims either directly with Scientemp Corp, 3565 S. Adrian Hwy, Adrian, MI 49221, or with the seller from whom the cabinet was purchased. All claims must be supported by information concerning the alleged defect and specifically identified by the Serial Number of the cabinet.

**THERE ARE NO OTHER WARRANTIES EXPRESS, IMPLIED, OR STATUTORY, EXCEPT THIS WARRANTY, WHICH IS IN LIEU OF ALL OTHER WARRANTIES INCLUDING TO THE EXTENT PERMITTED BY LAW, ANY IMPLIED WARRANTY OR MERCHANTABILITY OR FITNESS FOR A PARTICULAR PURPOSE.**

#### **DO NOT DRILL HOLES IN CABINET**

Refrigeration tubing and wiring is routed through the cabinet walls. Leaks, wet insulation or electrical problems caused by drilling holes are not covered by warranty.

SINGLE STAGE WIRING DIAGRAM WITH CAL9500, CHART RECORDER,  
 9 VOLT DUAL BATTERY ALARM, 115 VOLT/60/50HZ

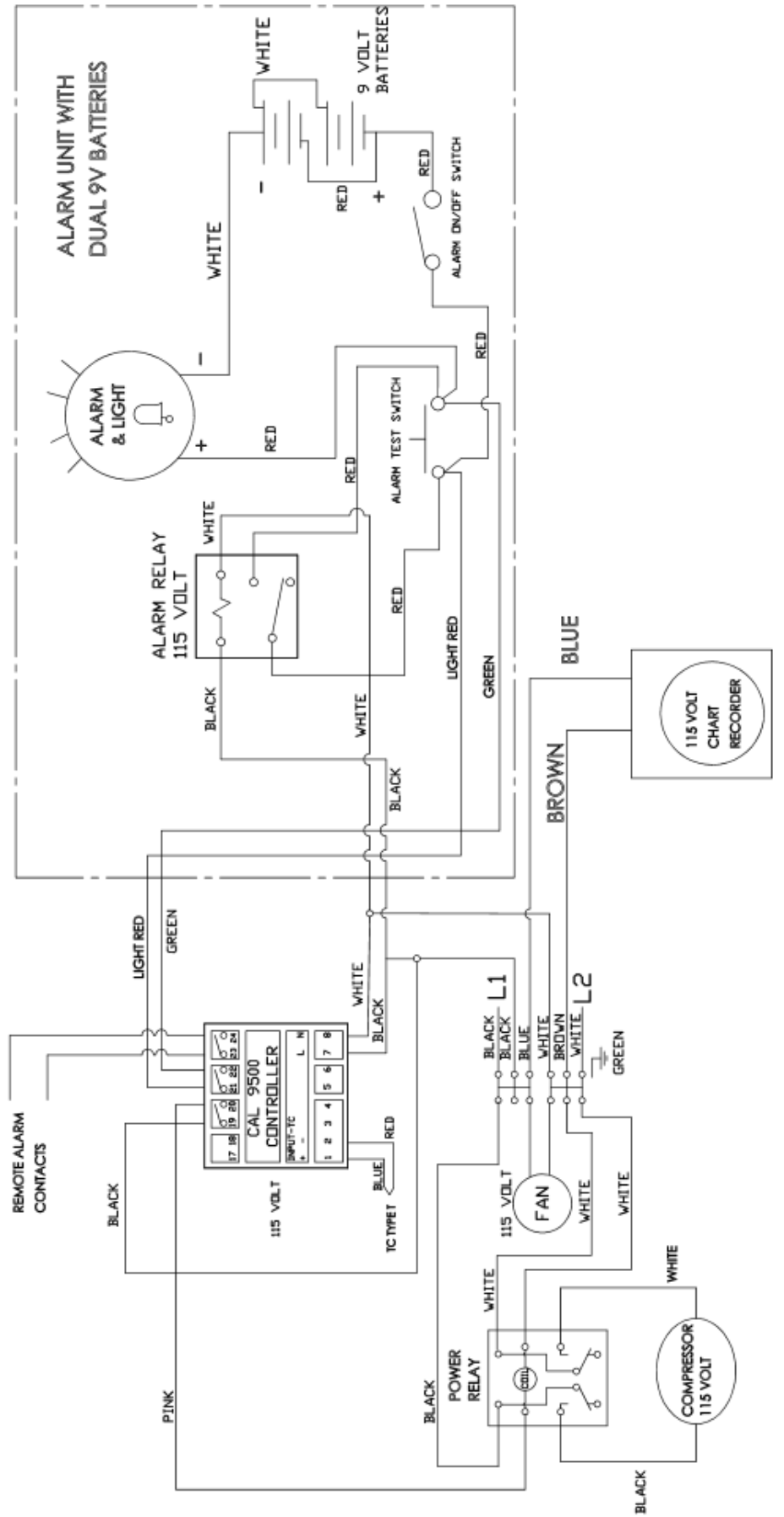

SINGLE STAGE WIRING DIAGRAM WITH CAL9500, CHART RECORDER,  
 9 VOLT DUAL BATTERY ALARM, 230 VOLT/60/50Hz

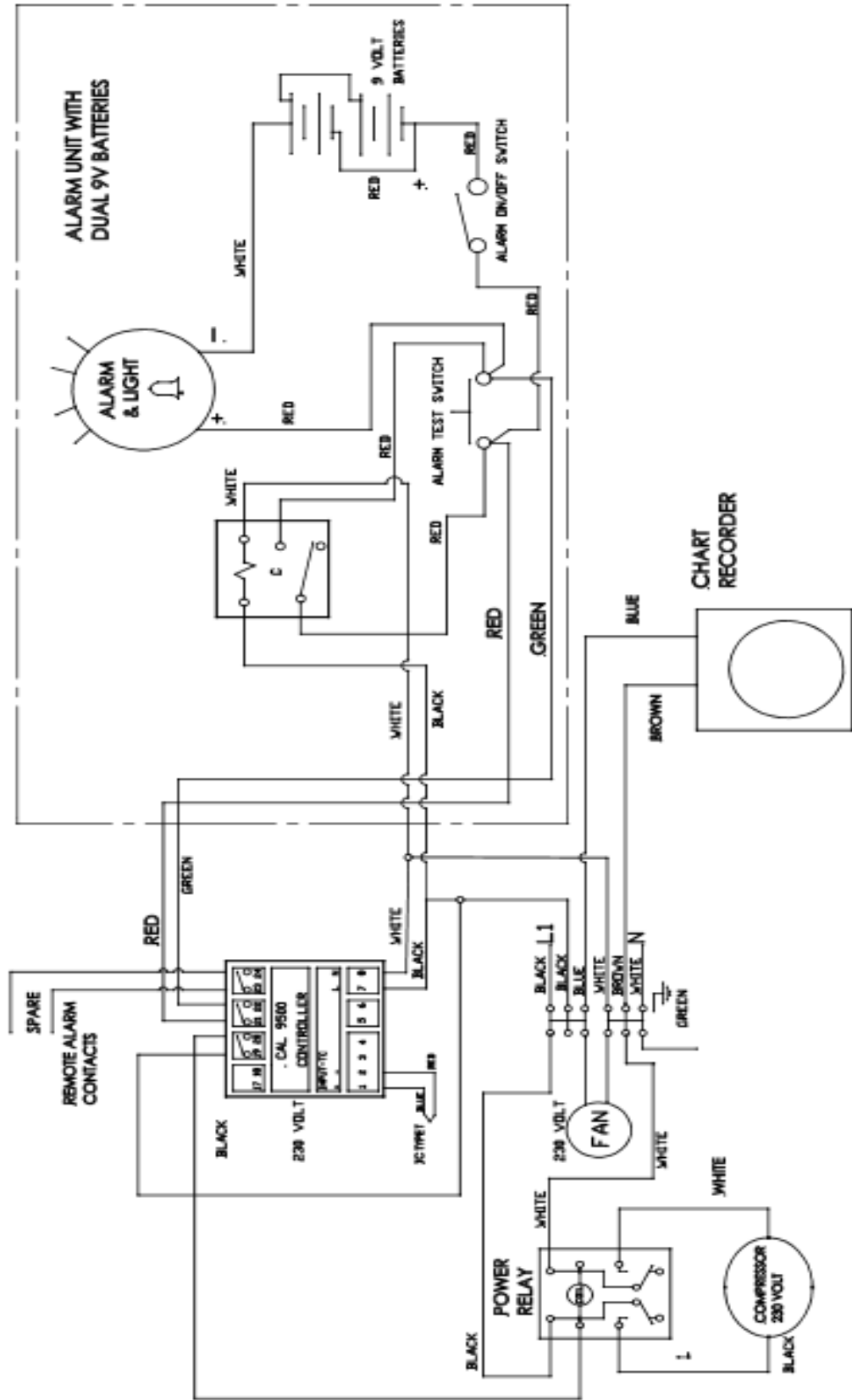

CASCADE WIRING DIAGRAM-CAL 9500 CONTROLLER, CHART RECORDER,  
 DUAL 9 VOLT BATTERY ALARM, 115VOLT/60HZ

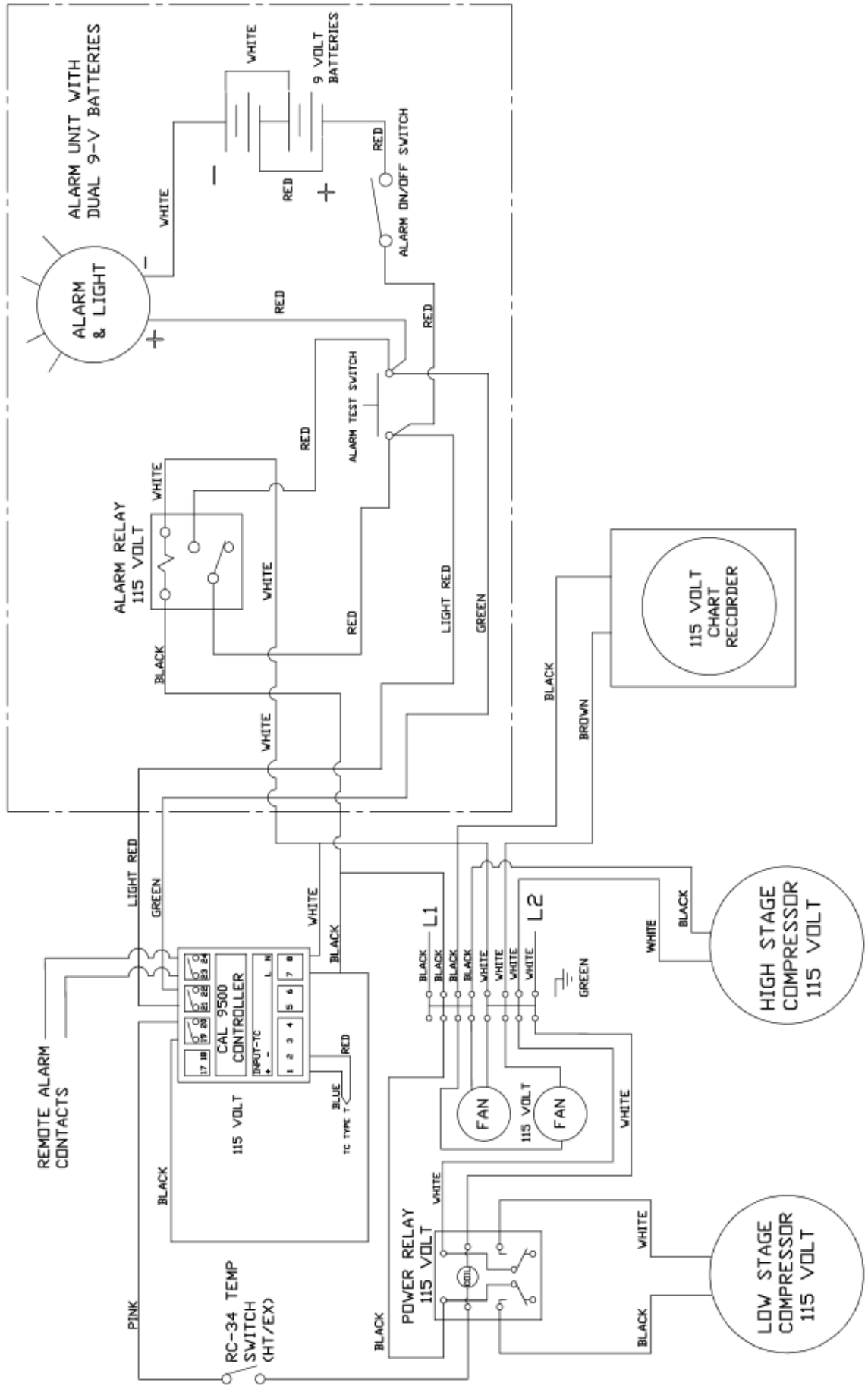

CASCADE WIRING DIAGRAM-CAL 9500 CONTROLLER, CHART RECORDER,  
 DUAL 9 VOLT BATTERY ALARM, 230VOLT/50/60Hz

